

Features

- **Wide Media Applications :**
Air, Gases, CNG, and Liquid relief applications.
 - **High Performance Soft Seat :**
provides repetitive & reliable bubble-tight seal.
 - **Orifice : 0.404 in. (10.26 mm)**
 - **Working Pressure : 6,000 psi (413 bar)**
 - **Cracking Pressure Range :**
15 to 5,500 psig (1.03 to 379 bar)
- Valves are supplied with protective painted surface.

Table 1. Materials of Construction

No.	Component	Valve Body Materials	
		Carbon Steel	Stainless Steel
1	Body	ASTM A216 Gr. WCB	ASTM A351 CF3M
2	Seat Frame	ASTM A105 or Equivalent	ASTM A479/A276 Type316
3	Cap	Carbon Steel	Stainless Steel
4	Cap O-Ring	Rubber	
5	Jam Nut	Carbon Steel	Stainless Steel
6	Flat Washer	Carbon Steel	Stainless Steel
7	Bonded Seal	NBR inner ring bonded to carbon steel outer ring	
8	Adjustable Screw	Carbon Steel with Cr Plated	Stainless Steel
9	Spring Keeper	Stainless Steel	
10	Spring	AISI 1086 or Equivalent	
11	Disc	ASTM A479/A276 Type316	
12	Seat Cap	ASTM A479/A276 Type316	
13	Seat Support	ASTM A479/A276 Type316	
14	Seat O-Ring	FKM (see Table 2 for optional O-rings)	
15	Insert Holder	ASTM A479/A276 Type316	
16	Body O-Ring	FKM (see Table 2 for optional O-rings)	
17	Lead Seal Wire	Stainless Steel	
18	Name Plate	Stainless Steel	
19	Rivet Bolt	Stainless Steel	

• Wetted parts are listed in blue.

V64 Series Technical Data

Working Pressure	Cracking Pressure Range	Orifice	Orifice Area
6,000 psig (413 bar)	15 to 5,500 psig (1.03 to 379 bar)	0.404 in. (10.26 mm)	0.128 in. ² (82.58 mm ²)

Table 2. Elastomer O-ring Technical Information

Component	Temp. Rating °F (°C)		Recommended Media
	Min.	Max.	
FKM (Viton)*	-15 (-26)	400 (204)	Hydrocarbons, H ₂ S, Mineral Oil/Grease, Silicone Oil/Grease, Fuels, Chlorinated Hydrocarbons.
HNBR	-25 (-31)	325 (162)	Hydrocarbons, CO ₂ , Dilute Acids, Water and Steam Less than 300 °F.
EPDM	-70 (-56)	250 (121)	Glycols, Organic Acids, Inorganic Acids, Hydraulic Fluids, Solvents.

* In case of CNG service, FKM of special compound is applied and temperature service is applicable to -40°F (-40°C).

Operation

When the inlet pressure overcomes the spring set pressure, it causes the valve to open, releasing flow to bypass and thereby balance the system pressure.

Factory Test

Every valve is factory tested for cracking and reseal performance.

Pressure Equipment Directive 97/23/EC Certifications

Module	B	D
Certificate No	HSBI-10-11-045	HSBI-10-11-046

Ordering Number and Dimensions

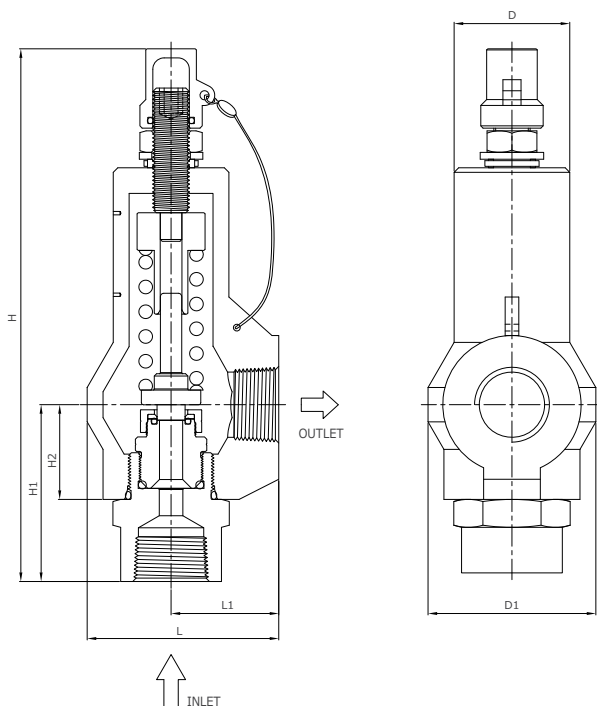

Table 3. Flow Rate

Flow rate measured by overpressure of 110% or 3 psig.

Media	Air	Gas	Water
Density	0.0764	0.0458	62.306
SG	1	0.6	1
Temp.	60 °F	60 °F	70 °F
Factor	Kd Factor 0.838	Kd Factor 0.838	K Factor 0.62
Set Pressure psig (bar)	SCFM	SCFM	GPM
15 (1.03)	64	80	13
20 (1.3)	74	93	14
25 (1.7)	84	105	16
30 (2.0)	94	117	17
50 (3.4)	137	171	22
100 (6.8)	245	306	32
150 (10.3)	353	441	39
200 (13.7)	462	576	45
250 (17.2)	570	711	50
300 (20.6)	678	846	55
400 (27.5)	894	1117	63
500 (34.4)	1111	1387	71
600 (41.3)	1327	1657	77
700 (48.2)	1543	1927	84
900 (62.0)	1976	2467	95
1000 (68.9)	2192	2737	100
1500 (103)	3274	4088	122
1750 (120)	3815	4763	132
2000 (137)	4355	5438	141
2500 (172)	5437	6789	158
3000 (206)	6519	8139	173
4000 (275)	8682	10840	200
4500 (310)	9763	12191	212
5000 (344)	10845	13541	224
5500 (379)	11927	14892	235

Table 4. Basic Ordering Number and Dimensions

Basic Ordering Number	End Connections		Dimensions in. (mm)							
	Inlet	Outlet	H	H1	H2	L	L1	D	D1	
V64-	F8N16N-	1/2 in. Female NPT	1 in. Female NPT	9.25 (235)	3.07 (78.0)	1.64 (41.8)	3.32 (84.50)	1.87 (47.5)	2.00 (51.0)	2.36 (60.0)
	F12N16N-	3/4 in. Female NPT								
	MF8N16N-	1/2 in. Male NPT								
	MF12N16N-	3/4 in. Male NPT								
	MF16N-	1 in. Male NPT								

Ordering Information

Select the desired valve basic ordering number in the table 4, applicable O-Ring designator, Spring designator, and Valve body material in the table below.

O-Ring Material Designators	Spring Set Pressure Designators Unit: psig	Valve Body Material Designators	Example of a complete ordering Number.
Applicable to components number of 14, and 16 in the table 1. • Nil: Standard FKM O-Ring • HBN: HNBR • EP: EPDM	<ul style="list-style-type: none"> • 1 : 15-40(Brown) • 2 : 41-100(Light Blue) • 3 : 101-215(Yellow) • 4 : 216-350(Light Green) • 5 : 351-750(Red) • 6 : 751 - 1000(Orange) • 7 : 1001 - 1800(Silver) • 8 : 1801 - 2800(Black) • 9 : 2801 - 3700(Dark Brown) • 10 : 3701 - 5500(Gray) 	<ul style="list-style-type: none"> • C: Carbon Steel • S: Stainless Steel 	V64-F12N16N-EP-8-C Factory Set Valve To order, specify the set pressure on the valve ordering number. i.e., V64-F-8N16N-1200-C

Safe Valve Selection

The selection of a valve for any application or system design must be considered to ensure safe performance. Valves function, valve rating, material compatibility, proper installation, operation and maintenance remain the sole responsibility of the system designer and the user. DK-Lok accepts no liability for any improper selection, installation, operation or maintenance.

© Copyright 2010-2013. All Rights Reserved.

 Fittings & Valves www.dklok.com	IDK-LOK Corporation Mailing Address 7, Golden root-ro 129beon-gil, Juchon-myeon, Gimhae-si, Gyeongsangnam-do, South Korea 621-842	DK-Lok contact information Tel. (82) 55-338-0114 Fax. (82) 55-901-0143 E-mail : sales@dklok.com	For International customers Tel. (82) 55-338-0031/2 Fax. (82) 55-901-0142 E-mail : dklok@dklok.com
--	---	--	---